

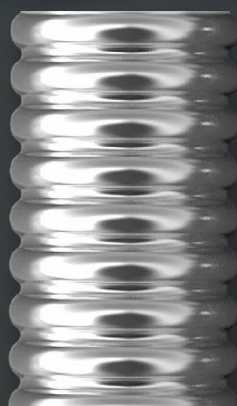

Corrugated Stainless Steel Tubes and Fittings





Contents

About SST Group	4
Manufacturing capabilities	6
Stahlmann stainless steel corrugated tubes	8
Applications	8
Advantages	10
Specifications.....	10
Corrugated tubes for gas supply	11
Corrugated tubes for water supply	12
Corrugated tubes for flared connection	13
Flaring tool	14
Product range	15
Stahlmann fittings	16
Specifications	16
Advantages	16
Design	17
Product range	18
Hydraulic loss table	21
Hazen-Williams equation	21
Our projects	22
Certificates and endorsements	24





About SST Group

SST Group, founded in 1991, is a leading global provider of electric heating cable solutions and manufacturer of ex-proof equipment. SST products and solutions can be found throughout Russia and are exported to over 40 countries worldwide.

SST Group is a vertically integrated holding that employs over 1 500 specialists. The Group encompasses four plants, an industrial R&D-center, an engineering company, several distribution companies and an international branch network.



Manufacturing of all critical components of electric heating systems



Own production of conductive plastics and self-regulating heating cables



International certification, including IECEx, ATEX, VDE



Extensive engineering and project management expertise as an EPC-contractor

- 27 years of success
- 1500 employees
- 4 own plants
- Offices in Russia, Germany, UAE, China, India
- Export to 47 countries

45 000 m²

production facilities

10 000

industrial heating systems installed

30 000 km

of corrugated tubing per year



Total length of electric heating cables produced by SST Group exceeds

1 300 000 km

3 times the distance from Earth to the Moon

5 500 000

units

of temperature control equipment

SST Group is the Only Russian Manufacturer of Corrugated Stainless Steel Tubes

In 2013, we launched serial production of flexible corrugated tubes Stahlmann made of high-alloyed SS304 stainless steel. Our manufacturing site is located in Moscow Region and is equipped with custom-built state-of-the-art technology.

Stahlmann corrugated tubes meet the highest international quality standards

High quality stainless steel is used in the manufacturing process. Polished steel tape is shaped into a tube, the edges are welded together, and the tube is then corrugated. 100% tightness of the weld – a prerequisite for the reliability and durability of the tube is ensured by a proven welding technology, hi-tech equipment, and compliance with cross-industry standards.

To make tubes flexible, they are annealed in a state-of-the-art induction furnace with a high feed rate.



Stahlmann corrugated tube fed for annealing



SS304 stainless steel tape used in the manufacture of corrugated tubes

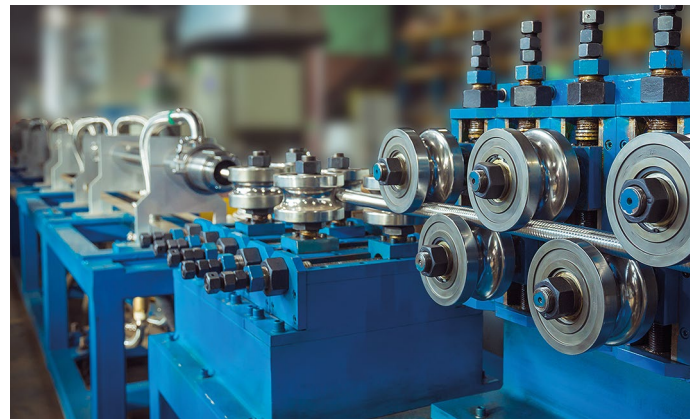

Stahlmann corrugated tube cooled after annealing

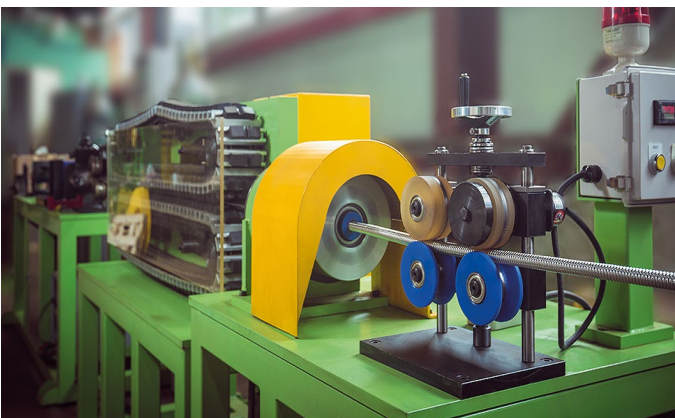

Tube corrugation process



Monitoring the annealing process of Stahlmann corrugated tubes

A broad range of corrugated tubes and quick-assembly fittings

We produce the following types of corrugated tubes:

- Annealed
- Unannealed
- Annealed in a yellow jacket for gas distribution systems
- Annealed in a white jacket for water supply systems

For connecting Stahlmann tubes, we offer a broad range of high-quality brass fittings of a unique quick assembly design, providing convenience and high speed of installation.

Proven quality and reliability

Stahlmann stainless steel flexible corrugated tubes and fittings come with all the necessary certificates and endorsements. Corrugated tubes have been tested for compliance with the applicable fire and industrial safety standards. Based on the test results, Stahlmann tubes and fittings are recommended for use in water and foam fire extinguishing systems.

All products undergo 100% quality control.

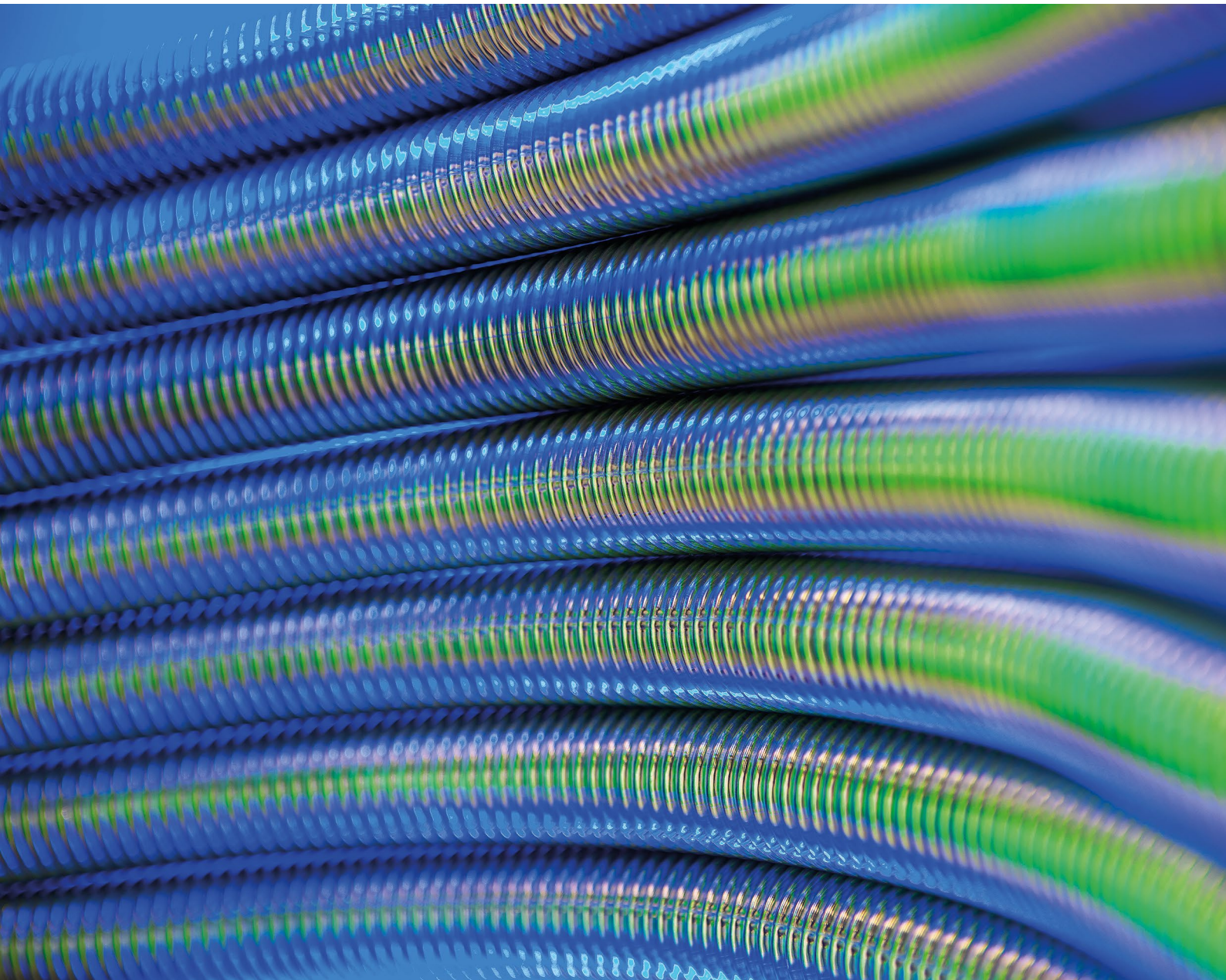

Stahlmann Corrugated Stainless Steel Tubes and Fittings

Applications:



Firefighting

Water supply lines to newly installed or relocated sprinklers. The use of corrugated tubes and fasteners allows installing the system in spaces with any layout, quickly and without the need for additional equipment. The only tools needed are a roller tube cutter and two wrenches.



Cable conduits

Corrugated steel tube is ideal for use as a sealed metal hose when laying power supply and communication networks. It reliably protects the cable from external mechanical and temperature impacts.



Gas distribution

Installation of flexible gas connectors. The product range includes corrugated tube in a yellow jacket and special fittings for gas distribution applications.

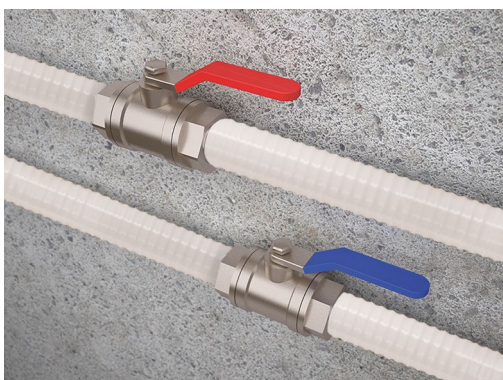

Water supply

Corrugated tubes in a white jacket and flexible connections are available for laying of cold and hot water pipelines and boiler tubing. The tube is corrosion-resistant, hydraulic impact-proof and comes with all the necessary certificates for use in potable water systems.



Heating

Laying of heating system tubes and connectors. The tube is resistant to temperature changes and corrosion, resistant to hydraulic impacts and has an improved heat transfer rating. Convenient for laying in confined spaces.



Hydronic underfloor heating

Due to its high thermal conductivity, Stahlmann tube is ideal for underfloor heating applications. Due to high flexibility of material, challenging configurations can be assembled with minimal effort. The tubes are resistant to freezing, do not require additional flushing and have a low linear expansion coefficient.



Air conditioning and ventilation

Tubing of fan coil units and air handling units. Annealed corrugated tubes provide quick installation and reliable connection.

13A, 18A

15A, 20A

15A, 20A

15A

20A

25A

32A

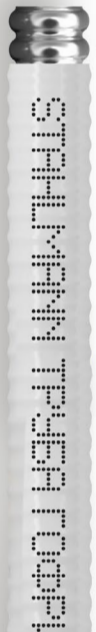

Advantages

- **A universal solution** for utility systems
- **Easy to cut and bend**, for easy installation
- Bending **does not alter the cross-section**, no microcracking and no mechanical stress on the metal occurs
- Annealed tubes **have improved plasticity and flexibility** and a significant safety margin for multiple bending
- **Resistant to aggressive environments**
- Linear expansion coefficient, when heated is **20 times lower** than in plastic tubes – an ideal solution for heating systems
- **Zero oxygen permeability** – the tube does not allow through oxygen, whose presence promotes the corrosion of other components of the heating system made of ordinary steel, such as radiators or boiler heat exchangers. Which translates into **increased service life** of the entire system
- **Environmental safety**, compatibility with drinking water, no risk of harmful substances being released when exposed to temperature fluctuations



Features of annealed corrugated tubes

Annealed corrugated tubes are flexible and easy to install, preventing unnecessary strain on the metal at the folds. Ideal for installation in challenging conditions.

Features of unannealed corrugated tubes

Ideal for straight stretches of long pipelines due to greater rigidity compared to annealed tubes.

Specifications

Parameter	Tube size (nominal bore)			
	15A	20A	25A	32A
Internal tube size, mm	14,1	21,0	27,0	32,0
Wall thickness, mm	0,3			
Corrugation crests, min. per 100 mm	20	19	18	18
External tube size, mm	18,1	25,6	32,0	37,6
Operating temperature at 1.5 MPa, °C	150			
Maximum short-term temperature, °C	400			
Operating pressure, MPa	1,5			
Minimum bending radius of an annealed tube, mm	30	40	50	80
Minimum bending radius of an unannealed tube, mm	40	50	60	90
Maximum (collapse) pressure at 20 °C, MPa	21			
Linear expansion coefficient 10 ⁻⁶ , 1/°C	17			
Thermal conductivity coefficient, W/m*K	17			
Service life	30 years			

Stahlmann Corrugated Stainless Steel Tubes for Gas Supply

Stahlmann tubes bend easily without the need for special tools, without any effect on the clear opening, and without the development of microcracks and putting mechanical stress on the metal

Stahlmann corrugated tubes in a yellow PE jacket are intended for use in gas supply systems. They can be used in internal gas supply pipelines or for connecting gas installations.

Stahlmann can be easily mounted within minutes, even in restricted spaces, without any effect on quality and reliability. For the complete assembly of a pipeline, an ordinary tube cutter and two spanner wrenches are needed.

For connections, Stahlmann dielectric gas brass couplings with an insulating ring are available. The ring prevents the metal parts of the fitting from coming into contact with the tube, ensuring safe operation of the pipeline.



Specifications

Parameter	Tube size (nominal bore)	
	15	20
Internal tube size, mm	14,1	21
External tube size, mm	19,1	26,6
Wall thickness, mm	0,3	
Insulation material	polyethylene	
Insulation thickness, mm	0,5	
Corrugation crests, min. per 100 mm	20	19
Operating temperature at 1.5 MPa, °C	90	
Min. temperature without pressure, °C	-40	
Maximum short-term temperature, °C	110	
Operating pressure, MPa	1,5	
Min. bending radius, mm	40	50
Length of a coil, m	50	
Maximum (collapse) pressure at 20 °C, MPa	21	
Linear expansion coefficient 10 ⁻⁶ , 1/°C	17	
Thermal conductivity coefficient, W/m*K	17	
Service life	20 years	

Stahlmann Corrugated Stainless Steel Tubes for Water Supply

High reliability, convenient and quick installation. White jacket for improved aesthetics. Stahlmann tubes in a white jacket can be bent easily without the need for special tools and preserve their shape, without kinking and clear opening reduction

Corrugated tubes in a white polyethylene jacket are intended for water supply and heating applications in residential and office buildings.

Stahlmann can be easily mounted within minutes, even in restricted spaces, without any effect on quality and reliability.

It is easy to secure a tube in the desired position without additional tools and equipment.

Tubes are connected by robust and reliable quick-assembly brass fittings for 100% leak tightness.

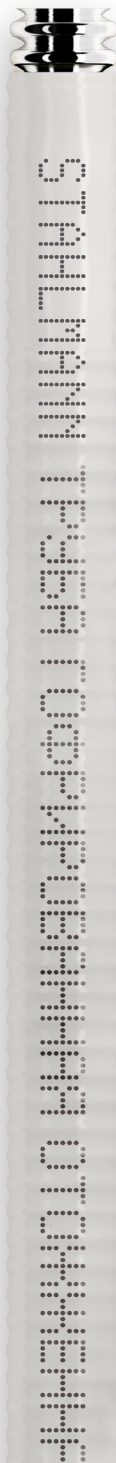

Specifications

Parameter	Tube size (nominal bore)	
	15	20
Internal tube size, mm	14,1	21
External tube size, mm	19,1	26,6
Wall thickness, mm	0,3	
Insulation material	polyethylene	
Insulation thickness, mm	0,5	
Corrugation crests, min. per 100 mm	20	19
Operating temperature at 1.5 MPa, °C	90	
Min. temperature without pressure, °C	-40	
Maximum short-term temperature, °C	110	
Operating pressure, MPa	1,5	
Min. bending radius, mm	40	50
Length of a coil, m	50	
Maximum (collapse) pressure at 20 °C, MPa	21	
Linear expansion coefficient 10 ⁻⁶ , 1/°C	17	
Thermal conductivity coefficient, W/m*K	17	
Service life	20 years	

Stahlmann Corrugated Stainless Steel Tubes for Flared Connection

Flexible connections on the basis of Stahlmann corrugated tubes ensure reliable and tight connection of water installations

Corrugated tubes Stahlmann are used for making flexible connections in water installations.

Flexible connections based on corrugated tubing provide high reliability and long service life. For 100% leak tightness, use original Stahlmann cap locknuts and gaskets.



Specifications

Parameter	Tube size (nominal bore)	
	13A	18A
Internal tube size, mm	12,4	16,0
Wall thickness, mm	0,3	
Corrugation crests, min. per 100 mm	21,5	20,5
External tube size, mm	16,1	20,0
Operating temperature at 1.5 MPa, °C	150	
Minimum temperature without pressure, °C	-60	
Operating pressure, MPa	1,5	
Minimum bending radius of an annealed tube, mm	33	45
Maximum (collapse) pressure at 20 °C, MPa	21	
Linear expansion coefficient 10 ⁻⁶ , 1/°C	17	
Thermal conductivity coefficient, W/m*K	17	
Service life	30 years	

Flaring Tool

1. When assembling flexible connections, we recommend using the universal Stahlmann flaring tool

- Compatible with tubes 13A and 18A, interchangeable head pieces are included
- Does not require the use of a hammer
- In-house production



How to make a flexible connection:

1. Use a roller tube cutter to cut off a portion of the corrugated tube of the required length for flaring.
2. Open the flaring tool's head piece and insert the corrugated tube so that the first corrugation of the tube extends beyond the stopper.
3. Close the head piece. With 5–6 return movements of the flaring tool handle, shape the end of the tube so that the first corrugation is flared.
4. Remove the tube from the tool.
5. Insert the corrugated tube into the head piece so that the second corrugation of the tube extends beyond the stopper. *Sequential flaring of the first and second corrugations gives a smoother tube end and a more reliable connection, compared to the two corrugations flared at once. **Important!** Put on both locknuts before flaring the second end of the tube.*
6. Flare the other end of the tube by following Steps 2–5. During the flaring process, the corrugated tube is shaped to form a stop ring for the cap locknut. After flaring, insert Stahlmann locknut gaskets of the matching diameter into the ends of the tube and tighten the locknuts with a wrench to the desired connection point.



Stahlmann Corrugated Tube Range

- Annealed
- Unannealed
- Annealed in a jacket (white, yellow)
- For flared connection

Nominal diameter: 13A, 15A, 18A, 20A, 25A, 32A,
Shipped as: convenient coils (10, 20, 30, 50, 100, 200 m)

Ordering information

Corrugated tube, stainless steel SS304 Stahlmann 15A,
unannealed, 10m
tube type |
coil length |
nominal diameter

Part	Stock no
Corrugated tube, stainless steel SS304 Stahlmann 15A, unannealed, 10 m	430613000012
Corrugated tube, stainless steel SS304 Stahlmann 15A, unannealed, 20 m	430613000013
Corrugated tube, stainless steel SS304 Stahlmann 15A, unannealed, 30 m	430613000014
Corrugated tube, stainless steel SS304 Stahlmann 15A, unannealed, 50 m	430613000015
Corrugated tube, stainless steel SS304 Stahlmann 15A, unannealed, 100 m	430613000011
Corrugated tube, stainless steel SS304 Stahlmann 15A, annealed, 10 m	430613000024
Corrugated tube, stainless steel SS304 Stahlmann 15A, annealed, 20 m	430613000025
Corrugated tube, stainless steel SS304 Stahlmann 15A, annealed, 30 m	430613000026
Corrugated tube, stainless steel SS304 Stahlmann 15A, annealed, 50 m	430613000027
Corrugated tube, stainless steel SS304 Stahlmann 15A, annealed, 100 m	430613000023
Corrugated tube, stainless steel SS304 Stahlmann 20A, unannealed, 10 m	430613000030
Corrugated tube, stainless steel SS304 Stahlmann 20A, unannealed, 20 m	430613000031
Corrugated tube, stainless steel SS304 Stahlmann 20A, unannealed, 30 m	430613000032
Corrugated tube, stainless steel SS304 Stahlmann 20A, unannealed, 50 m	430613000033
Corrugated tube, stainless steel SS304 Stahlmann 20A, annealed, 10 m	430613000041
Corrugated tube, stainless steel SS304 Stahlmann 20A, annealed, 20 m	430613000042
Corrugated tube, stainless steel SS304 Stahlmann 20A, annealed, 30 m	430613000043
Corrugated tube, stainless steel SS304 Stahlmann 20A, annealed, 50 m	430613000044
Corrugated tube, stainless steel SS304 Stahlmann 20A, annealed, 100 m	430613000040
Corrugated tube, stainless steel SS304 Stahlmann 25A, unannealed, 10 m	430613000045
Corrugated tube, stainless steel SS304 Stahlmann 25A, unannealed, 20 m	430613000046
Corrugated tube, stainless steel SS304 Stahlmann 25A, unannealed, 30 m	430613000047
Corrugated tube, stainless steel SS304 Stahlmann 25A, annealed, 10 m	430613000054
Corrugated tube, stainless steel SS304 Stahlmann 25A, annealed, 20 m	430613000055
Corrugated tube, stainless steel SS304 Stahlmann 25A, annealed, 30 m	430613000056
Corrugated tube, stainless steel SS304 Stahlmann 32A, unannealed, 10 m	430613000067
Corrugated tube, stainless steel SS304 Stahlmann 32A, unannealed, 20 m	430613000068
Corrugated tube, stainless steel SS304 Stahlmann 32A, annealed, 10 m	430613000070
Corrugated tube, stainless steel SS304 Stahlmann 32A, annealed, 20 m	430613000075
Corrugated tube, stainless steel SS304 Stahlmann 15A, annealed, white jacket, 50 m	43059210000071
Corrugated tube, stainless steel SS304 Stahlmann 20A, annealed, white jacket, 30 m	430613000075
Corrugated tube, stainless steel SS304 Stahlmann 15A, annealed, yellow jacket, 50 m	430613000074
Corrugated tube, stainless steel SS304 Stahlmann 20A, annealed, yellow jacket, 30 m	430613000076
Corrugated tube, stainless steel SS304 Stahlmann 13A, annealed, 20 m	430613000009
Corrugated tube, stainless steel SS304 Stahlmann 18A, annealed, 20 m	430613000029

Navigating the product range

Coil length	Nominal diameter	15A			20A			25A		32A		13A	18A
	Tube type	annealed	unannealed	annealed in a jacket	annealed	unannealed	annealed in a jacket	annealed	unannealed	annealed	unannealed	for flared connection	
10 m		+	+		+	+		+	+	+	+		
20 m		+	+		+	+		+	+	+	+	+	+
30 m		+	+	+	+	+	+	+	+				
50 m		+	+	+	+	+	+						
100 m		+	+		+								
200 m		+											

Stahlmann Fittings

Special design based on a high-strength self-tightening ring



To ensure the tight installation of Stahlmann corrugated tube-based systems, we offer an extensive range of original fittings.

Fittings are made of high quality CW617N brass.

The distinctive feature of the fittings is their custom design developed by SST and allowing the part to be fitted to the tube in a matter of seconds.

To install the fitting, simply insert the tube into it and tighten the locknut. No disassembly of the fitting is required.

All Stahlmann fittings are certified. Thanks to the high-quality materials used in the manufacture of Stahlmann fittings, they provide a high degree of dust and moisture protection, temperature resistance (to both high and low temperatures), resistance to sparks, rodents, fungus, mold.

Specifications

Parameter	Fitting size for water supply				Fitting size for gas supply		
	15 A	20 A	25 A	32 A	15 A	20 A	25 A
Body and locknut material	Brass CW617N / LS59-1C						
Body and locknut coating*	Nickel				-		
Thread size, inches	½	¾	1	1¼	½	¾	1
Operating temperature, °C	-50 ... +110 (-50 ... +160**)				-20 ... +100		
Operating pressure, MPa	1,5	1,2	1,0	1,0	1,5	1,2	1,0
Maximum short-term temperature, °C	150				-		
Maximum short-term pressure, MPa	5	4	3,5	2,5	-		
Service life					30 years		
Warranty					2 years		

* – fittings can be either coated or uncoated

** – when using high-temperature silicone rubber gaskets (to be ordered separately)

Advantages

- Manufacturing method – hot forging
- Material of the coupling and lock ring is CW617N brass (58–59% copper, providing maximum strength and ductility)
- Clamping ring of stainless steel AISI 304
- Both nickel-plated and uncoated fittings are available

Quick-Assembly Fitting Design

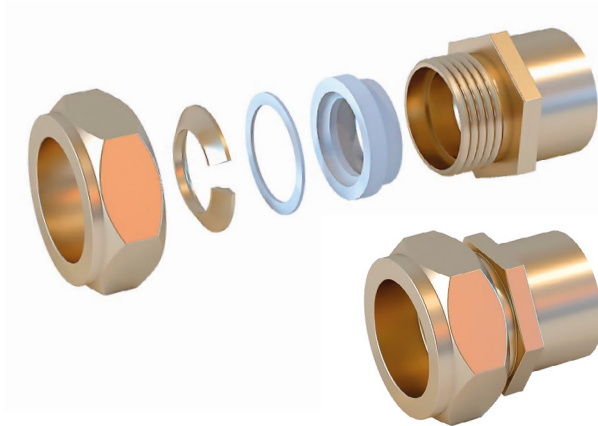
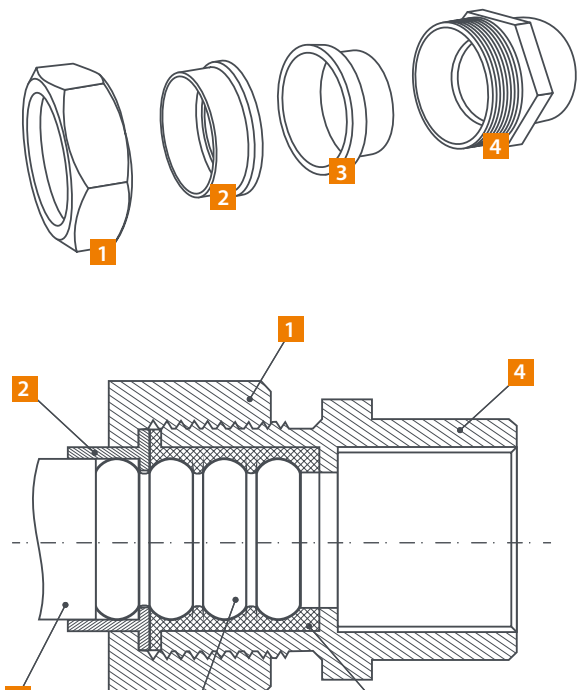

1. Coupling locknut
2. Self-locking ring of brass CW617N
3. Clamping ring
4. Silicone seal
5. Body
6. Stainless steel corrugated tube

Design of Fittings for Gas Supply

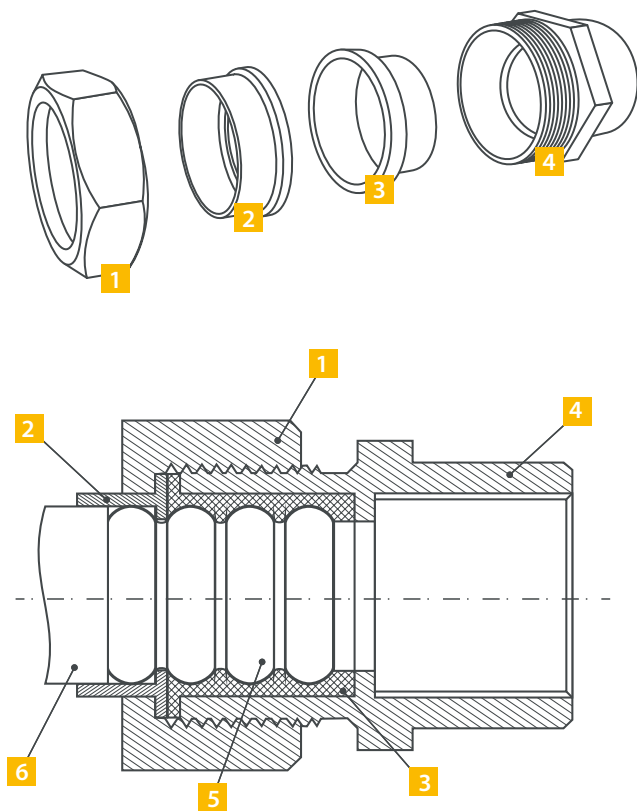

1. Coupling locknut
2. Retaining ring of polyamide (nylon)
3. Fluoric rubber (FPM) dielectric ring
4. Body
5. Stainless steel corrugated tube, no jacket
6. Stainless steel corrugated tube, plastic jacket

Stahlmann Fitting Range



Coupling (F)
 15x 1/2 EF 20x 3/4 EF
 15x 1/2 HΠ EF 20x 3/4 HΠ EF
 15x 3/4 EF 25x1 EF
 20x1/2 EF 32x1 1/4 EF



15 x 3/4 EF Euro cone for connecting a corrugated tube to a water floor heating manifold



Coupling (M)
 15x 1/2 EF 20x 3/4 EF
 15x 1/2 HΠ EF 20x 3/4 HΠ EF
 15x 3/4 EF 25x1 EF
 32x1 1/4 EF 20x1/2 EF



Coupling
 15x15 EF 20x15 EF
 20x20 EF 25x15 EF
 25x25 EF 25x20 EF
 32x32 EF



T-joint Stahlmann (F)
 15 x 1/2 x 15 EF
 20 x 3/4 x 20 EF
 25 x 1 x 25 EF
 32 x 1 1/4 x 32 EF



T-joint (M)
 15 x 1/2 x 15 EF



T-joint
 15 x 15 x 15 EF
 20 x 20 x 20 EF
 25 x 25 x 25 EF



Angle piece
 15 x 1/2 EF
 20 x 3/4 EF
 25 x 1 EF



Coupling locknut
 1/2
 3/4
Silicone locknut gasket
 1/2
 3/4



Angle piece (M)
 15x 1/2 EF



Angle piece with a fastener
 15 x 1/2 EF
 20 x 3/4 EF



Coupling (F) gas
 15 x 1/2
 20 x 3/4
 25 x 1



Coupling (M) gas
 15 x 1/2
 20 x 3/4
 25 x 1



Lock ring, stainless steel
 DN15 DN25
 DN20 DN32



Silicone gasket
 DN15 DN25
 DN20 DN32
High temperature gasket
 DN15 DN25
 DN20 DN32



Ball valve (M)
 15 x 1/2 NP EF



Ball valve (F)
 15 x 1/2 NP EF

Mounts for automatic fire extinguishing systems

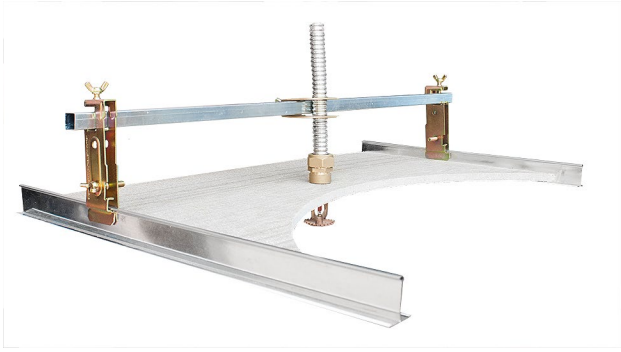

Complete mounts for automatic fire extinguishing systems



Tube bracket
Stahlmann Bracket L

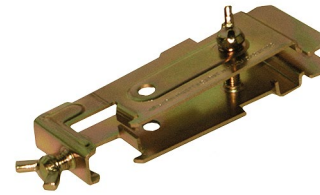

Rail bracket
Stahlmann Bracket S



Tube rail SQR



Clamp for 15x $\frac{1}{2}$ "
Stahlmann fitting

15x $\frac{1}{2}$ groove EF
(grooved fitting for fire
extinguishing systems)

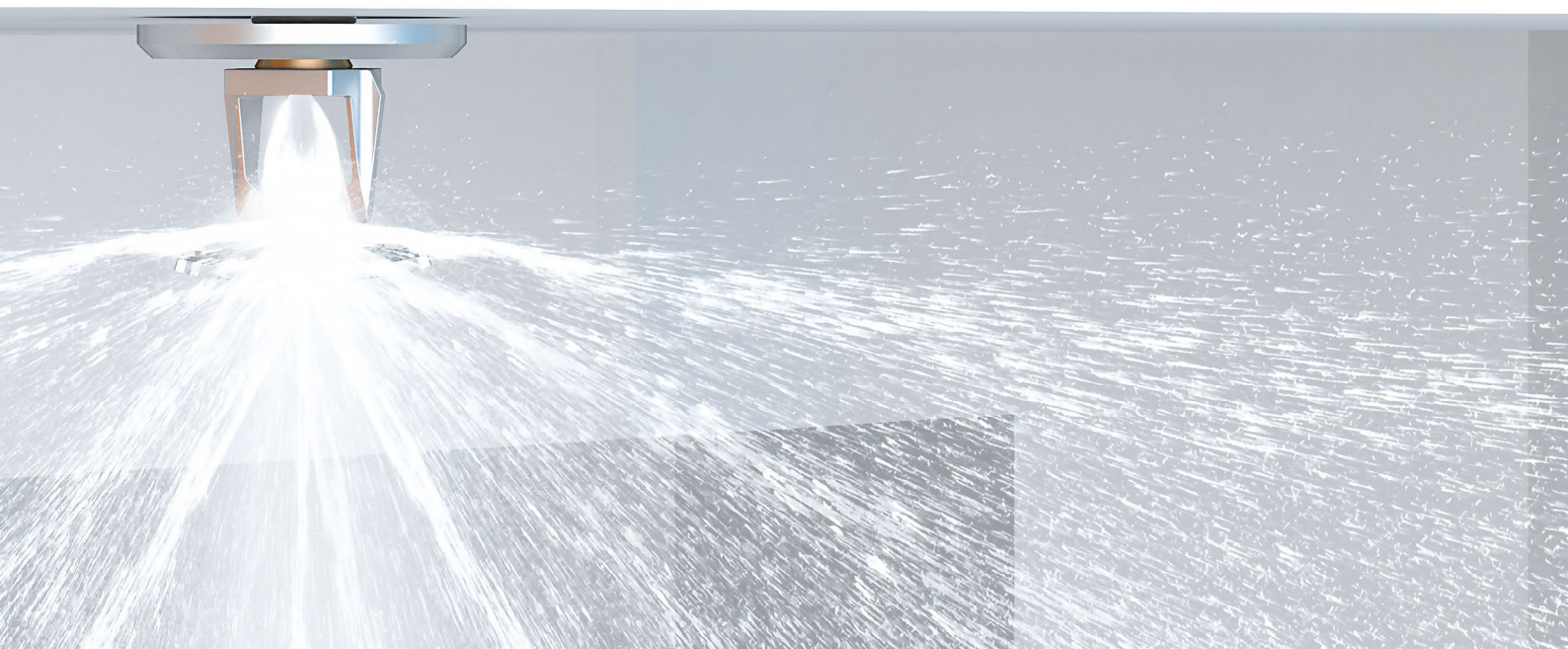
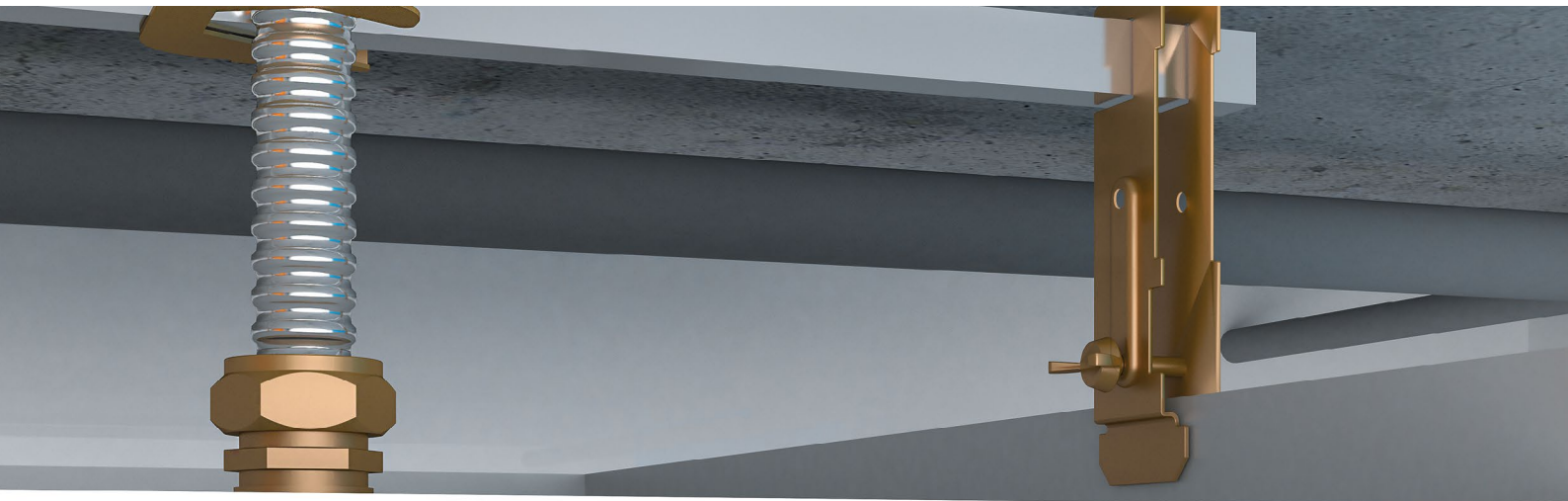

Item	Stock no.
Coupling Stahlmann (F) 15x1/2 EF	100279000026
Coupling Stahlmann (F) 15x1/2 НП EF	100279000028
Coupling Stahlmann (F) 15x3/4 EF	100279000029
Coupling Stahlmann (F) 15x3/4 EF Euro Cone	100279000030
Coupling Stahlmann (F) 20x3/4 EF	100279000032
Coupling Stahlmann (F) 20x1/2 EF	100279000031
Coupling Stahlmann (F) 20x3/4 НП EF	100279000034
Coupling Stahlmann (F) 25x1 EF	100279000035
Coupling Stahlmann (F) 32x1 1/4 EF	100279000036
Coupling Stahlmann (M) 15x1/2 EF	100279000041
Coupling Stahlmann (M) 15x1/2 НП EF	100279000042
Coupling Stahlmann (M) 15x3/4 EF	100279000043
Coupling Stahlmann (M) 20x3/4 EF	100279000045
Coupling Stahlmann (M) 20x1/2 EF	100279000044
Coupling Stahlmann (M) 20x3/4 НП EF	100279000047
Coupling Stahlmann (M) 25x1 EF	100279000048
Coupling Stahlmann (M) 32x1 1/4 EF	100279000049
Coupling Stahlmann 15x15 EF	100279000054
Coupling Stahlmann 20x20 EF	100279000056
Coupling Stahlmann 25x25 EF	100279000060
Coupling Stahlmann 32x32 EF	100279000061
Coupling Stahlmann 20*15 EF	100279000055
Coupling Stahlmann 25*15 EF	411066000068
Coupling Stahlmann 25*20 EF	100279000059
T-joint Stahlmann (F) 15x1/2x15 EF	100279000074
T-joint Stahlmann (F) 20x3/4x20 EF	100279000075
T-joint Stahlmann (F) 25x1x25 EF	100279000076
T-joint Stahlmann (F) 32x1 1/4x32 EF	100279000077
T-joint Stahlmann (M) 15x1/2x15 EF	100279000078
T-joint Stahlmann 15x15x15 EF	100279000080
T-joint Stahlmann 20x20x20 EF	100279000081
T-joint Stahlmann 25x25x25 EF	100279000083
Angle joint Stahlmann 15x1/2 EF	100279000085
Angle joint Stahlmann 20x3/4 EF	100279000086

Item	Stock no.
Angle joint Stahlmann 25x1 EF	100279000087
Angle joint Stahlmann (M) 15x1/2 EF	100279000084
Angle joint Stahlmann with fasteners 15 x 1/2 EF	100279000089
Angle joint Stahlmann with fasteners 20x3/4 EF	100279000090
Coupling Stahlmann (F) gas 15x1/2	100279000037
Coupling Stahlmann (F) gas 20x3/4	100279000038
Coupling Stahlmann (F) gas 25x1	100279000039
Coupling Stahlmann (M) gas 15x1/2	100279000050
Coupling Stahlmann (M) gas 20x3/4	100279000051
Coupling Stahlmann (M) gas 25x1	100279000052
Lock ring, stainless steel, Stahlmann, DN15	100279000021
Lock ring, stainless steel, Stahlmann, DN20	100279000022
Lock ring, stainless steel, Stahlmann, DN25	100279000023
Lock ring, stainless steel, Stahlmann, DN32	100279000024
Silicone gasket Stahlmann, DN15	100279000068
Silicone gasket Stahlmann, DN20	100279000069
Silicone gasket Stahlmann, DN25	100279000070
Silicone gasket Stahlmann, DN32	100279000071
High temperature gasket Stahlmann, DN15	100279000015
High temperature gasket Stahlmann, DN20	100279000016
High temperature gasket Stahlmann, DN25	411071000010
High temperature gasket Stahlmann, DN32	411071000011
Silicone locknut gasket Stahlmann 1/2	100279000072
Silicone locknut gasket Stahlmann 3/4	100279000073
Ball valve Stahlmann (M) 15x1/2 NP EF	100279000093
Ball valve Stahlmann (F) 15x1/2 NP EF	100279000092
Coupling Stahlmann (F) 15x1/2 groove EF	100279000027
Tube bracket Stahlmann Bracket L	100282000001
Rail bracket Stahlmann Bracket S	100282000002
Tube rail SQR	411064000003
Clamp for 15x1/2" Stahlmann fitting	100282000003
Coupling locknut Stahlmann 1/2	100279000019
Coupling locknut Stahlmann 3/4	100279000020

Ordering information

Coupling Stahlmann (F) 15x1/2 НП EF

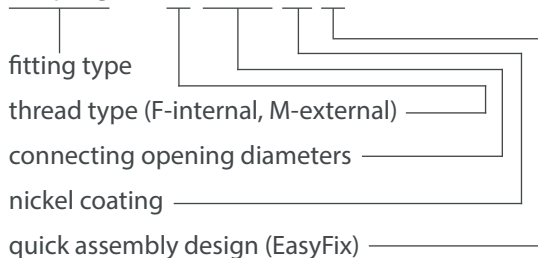

Hydraulic Loss Table for Stahlmann Stainless Steel Corrugated Tubes

Nominal diameter	15A	Flow, m ³ /h	0,3	0,8	1,4	2	2,5	3	3,5	4	4,6
		Drop, bar/m		0,002	0,017	0,0441	0,0834	0,1471	0,1863	0,2648	0,3138
20A	Flow, m ³ /h		0,4	1,2	2,3	3,4	4,5	5,5	6,6	7,7	8,8
	Drop, bar/m		0,0007	0,0064	0,0196	0,0343	0,0637	0,0932	0,1471	0,1863	0,2354
25A	Flow, m ³ /h		0,5	2,2	3,8	5,4	7,1	8,7	10,4	11,7	13,6
	Drop, bar/m		0,0004	0,0059	0,0177	0,0324	0,0461	0,0765	0,1177	0,1471	0,1667
32A	Flow, m ³ /h		0,8	2,7	4,6	6,5	8,5	10,4	12,3	14,2	16,4
	Drop, bar/m		0,0004	0,0042	0,0137	0,0206	0,0343	0,0539	0,0686	0,0883	0,1275

Hazen-Williams Equation for Stahlmann Corrugated Tubes

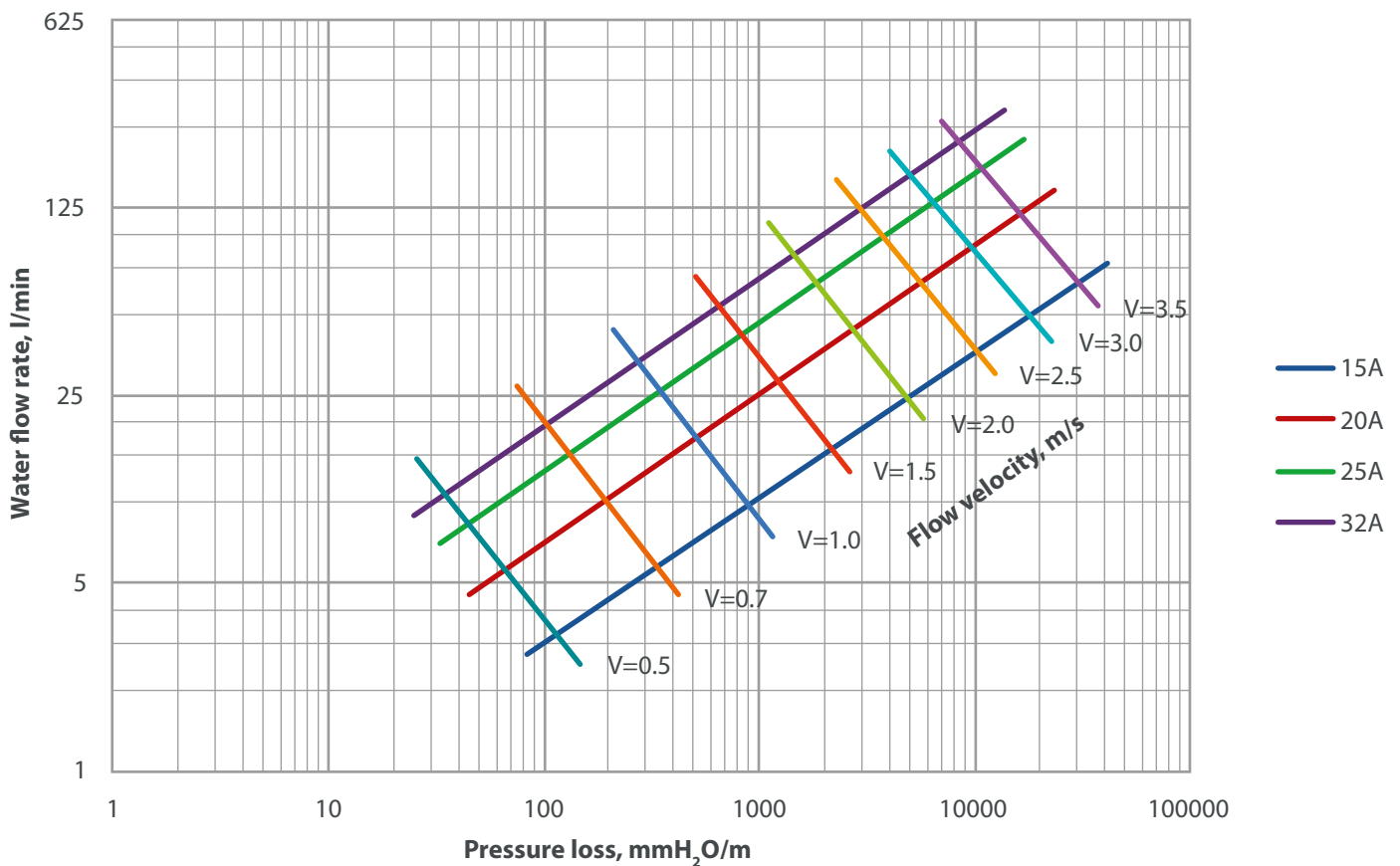

Our Projects



Passage Department Store in St. Petersburg



Nizhny Novgorod International Airport



Luzhniki Sports Complex



Samara Arena Stadium



Nizhny Novgorod Stadium



Vostok Tower in Moscow International Business Center



Maxidom DIY Store in St. Petersburg

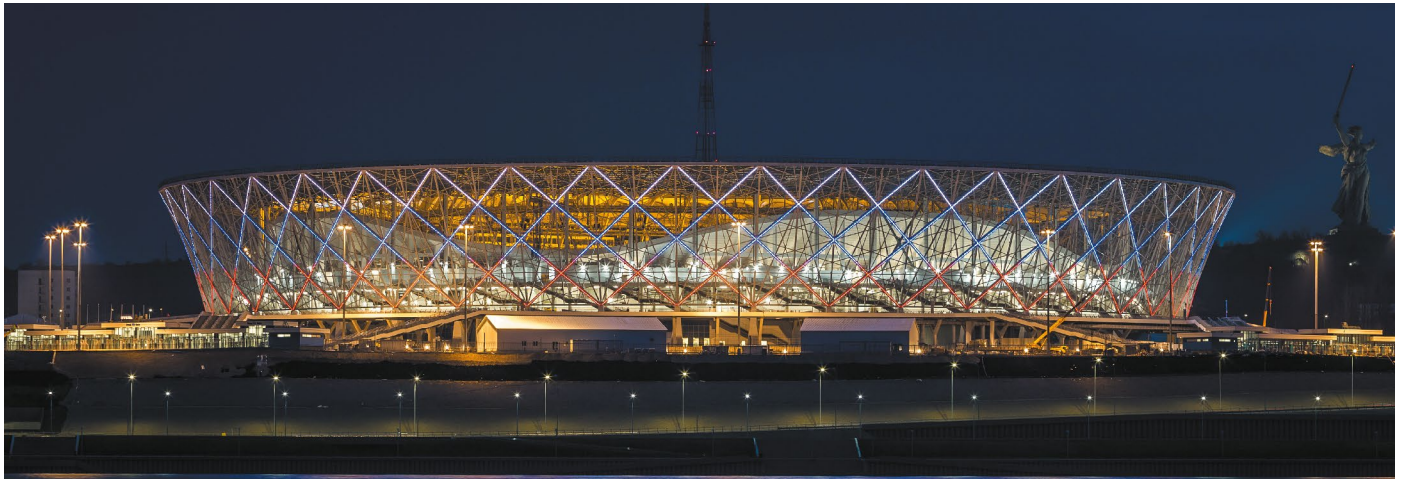

Volgograd Arena Stadium



Almaz Shopping and Entertainment Complex in Chelyabinsk



Vidgof Grand Hotel and Bovid Business Center in Chelyabinsk

Certificates and Endorsements

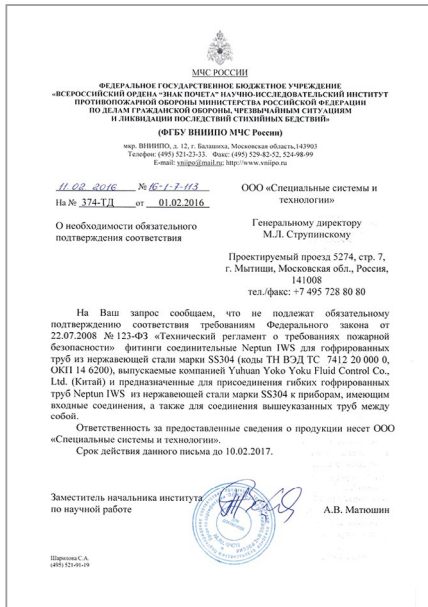

VNIPO exemption for connecting fittings



Expert report on conformity to the Consolidated Sanitary Requirements



Certificate of state registration of product conformity with the Consolidated Public Health and Hygienic Standards for Connecting Fittings

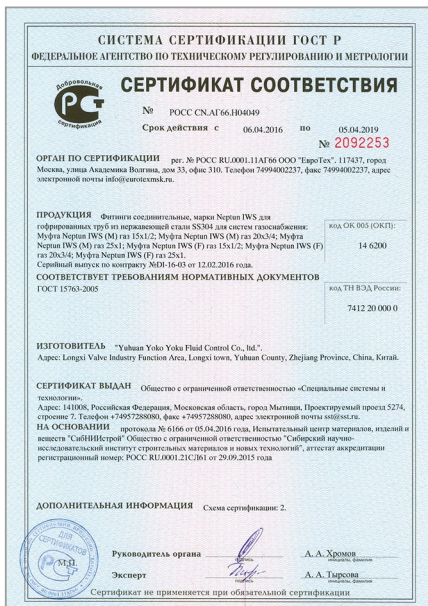

Certificate of conformity GOST R for connecting fittings for gas supply applications

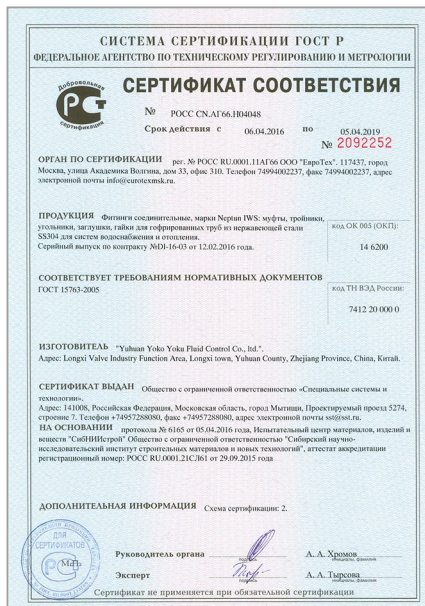

Certificate of conformity GOST R for connecting fittings for water supply and heating applications

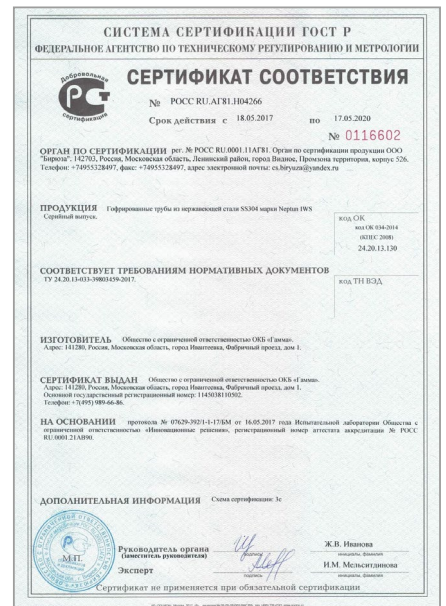

Certificate of conformity GOST R for corrugated tubes



Certificate of conformity to industrial safety standards for corrugated tubes



Certificate of conformity to industrial safety standards for fittings



Certificate of conformity to fire safety regulations for corrugated tubes



Certificate of conformity with fire safety regulations for fittings

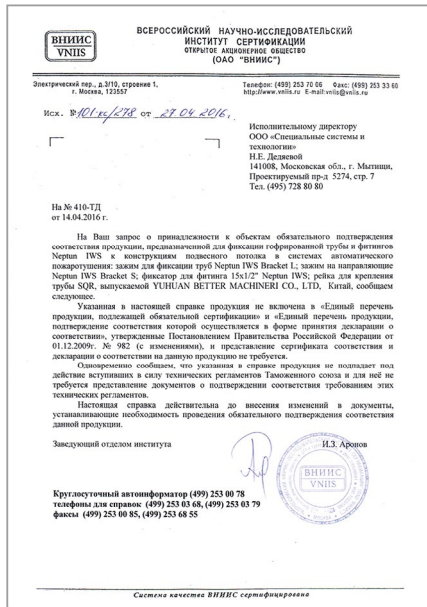

VNIIS exemption for installation fasteners of automatic fire extinguishing systems



VNIPO exemption for high-temperature gaskets

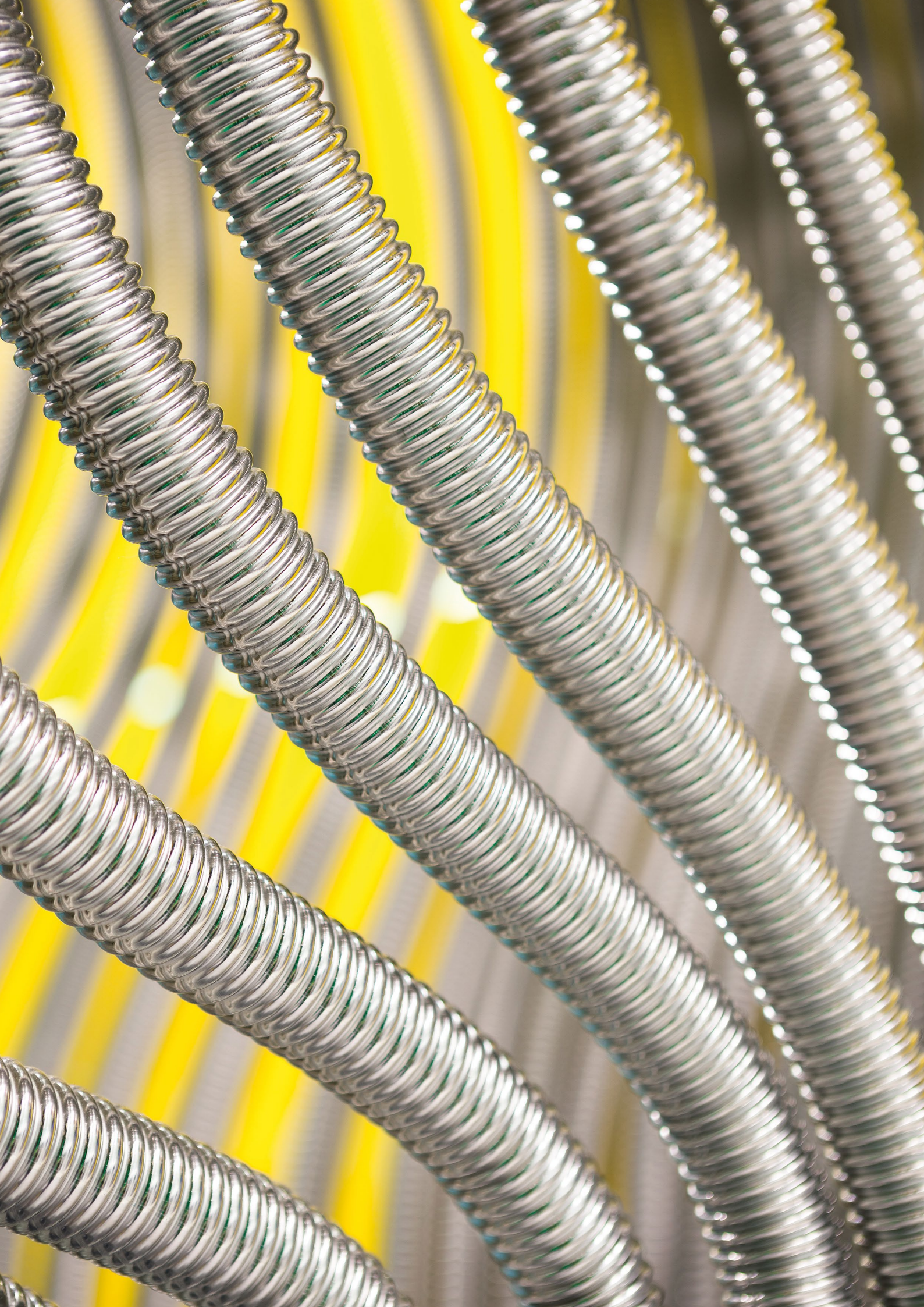

**Head Office**

Proiektiruemiy proezd 5274, bld. 7
Mytishchi, Moscow region,
141008, Russia
Phone: +7 495 728-80-80, +7 495 780-70-13
sst@sst.ru

SST Energomontazh (industrial solutions)

Kolpakova street 2,
Mytishchi, Moscow region,
141002, Russia
Phone: +7 495 627-72-55
info@sst-em.ru

European Office

SST GmbH
i_Park Tauberfranken 18,
97922 Lauda-Königshofen, Germany
Phone: +49 9343 98091-00
info@sst-international.com

SST Thermal Solutions ME-FZCO

2303, HDS Business Centre, Cluster M
Jumeirah Lakes Towers
Dubai, United Arabian Emirates
Phone: +971 54444-12-05, +971 56971-22-66
sales-me@sst-international.com

www.sst.ru/en